

F Chromatic
Bells

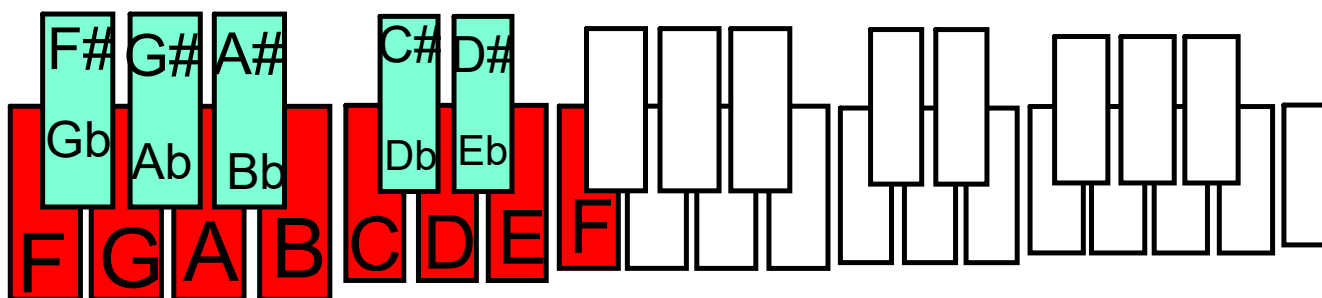

CONCERT F

Bells

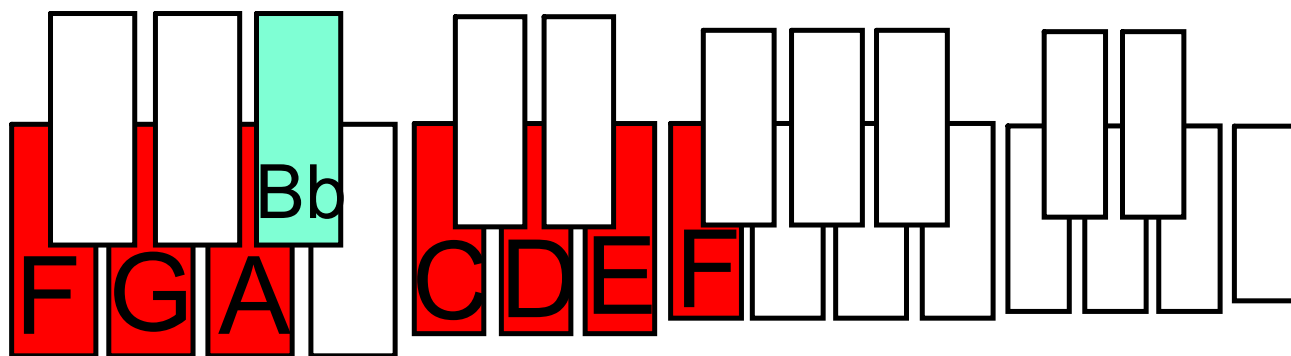

Concert F- Scale

Concert F- Arpeggio

Do Mi So Do Ti So Fa Re Do

6 Concert F- Thirds

CONCERT Bb

Bells

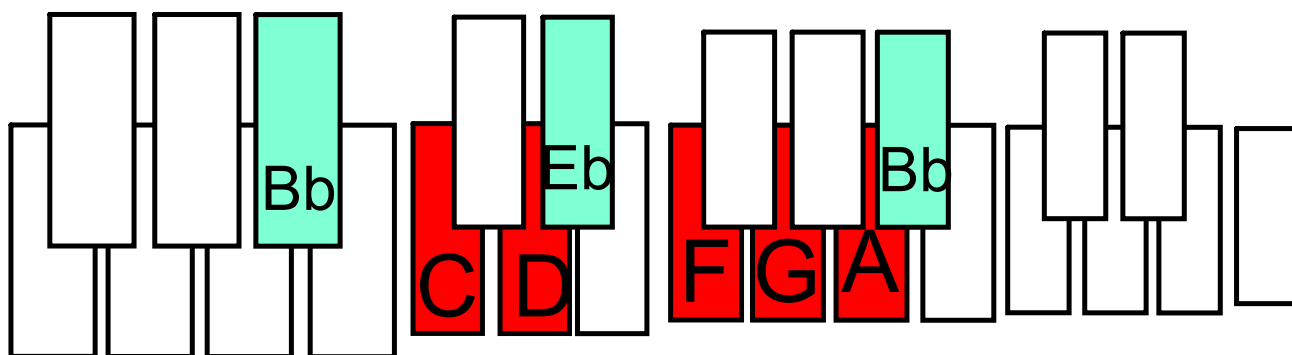

10 Concert Bb- Scale

Concert Bb- Arpeggio

Do Mi So Do Ti So Fa Re Do

15 Concert Bb- Thirds

CONCERT Eb

Bells

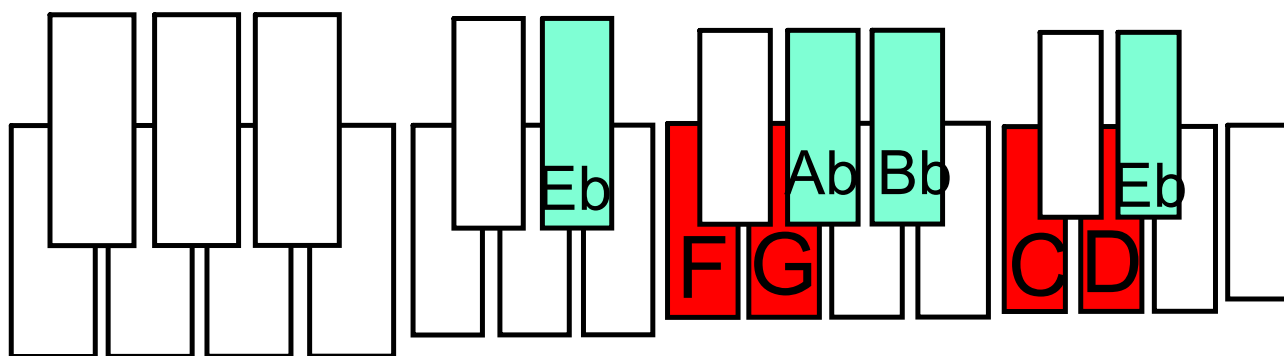

19 Concert Eb- Scale

Concert Eb- Arpeggio

Do Mi So Do Ti So Fa Re Do

The first staff shows the Concert Eb- Scale starting at measure 19. The second staff shows the Concert Eb- Arpeggio starting at measure 23, with the lyrics "Do Mi So Do Ti So Fa Re Do" written below the notes.

24 Concert Eb- Thirds

The third staff shows the Concert Eb- Thirds starting at measure 24. The notes are played in pairs of thirds.

CONCERT Ab

Bells

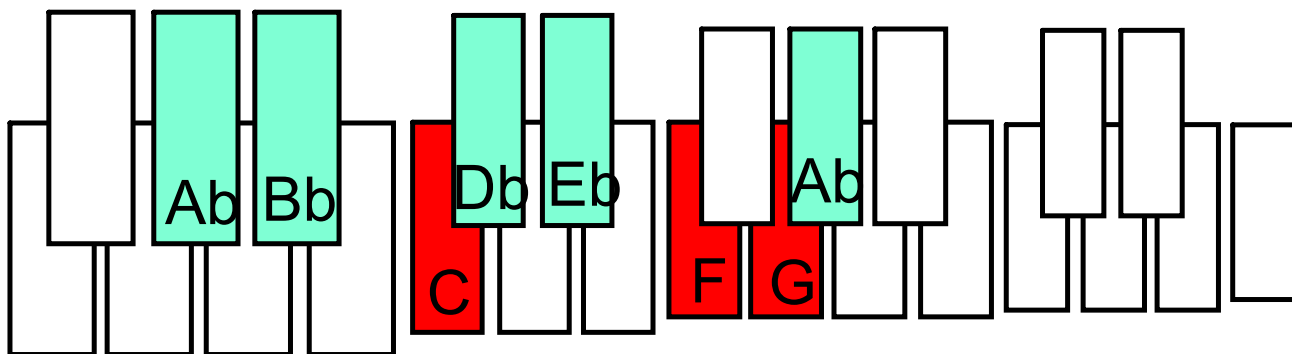

28 Concert Ab- Scale

Concert Ab- Arpeggio

Do Mi So Do Ti So Fa Re Do

Musical notation for the Concert Ab- Scale and Concert Ab- Arpeggio. The scale is written in a treble clef with a key signature of three flats (Bb, Eb, Ab). The arpeggio is written in a treble clef with a key signature of three flats (Bb, Eb, Ab) and includes the lyrics: Do Mi So Do Ti So Fa Re Do.

33 Concert Ab- Thirds

Musical notation for the Concert Ab- Thirds exercise, written in a treble clef with a key signature of three flats (Bb, Eb, Ab).